

able.

LN-Series MEDIUM

I

**ATTUATORE
ELETTROMECCANICO
IRREVERSIBILE PER CANCELLI A
BATTENTE**

P

**ACTUADOR ELECTROMECHANICO
IRREVERSÍVEL PARA PORTÕES
DE BATENTE**

GB

**IRREVERSIBLE
ELECTROMECHANICAL
ACTUATOR FOR SWING GATES**

D

**NICHT UMKEHRBARER
ELEKTROMECHANISCHER
ANTRIEB FÜR FLÜGELTORE**

F

**OPERATEUR
ELECTROMECHANIQUE
IRREVERSIBLE POUR
PORTAILS BATTANTS**

NL

**ELEKTROMECHANISCHE,
ONOMKEERBARE LINEAIRE
MOTOR VOOR HEKKEN MET
VLEUGELS**

E

**OPERADOR ELECTROMECHANICO
IRREVERSIBLE PARA
CANCELAS BATIENTES**

PL

**ELEKTROMECHANICZNY
NIEODWRACALNY SIŁOWNIK
DO BRAM SKRZYDŁOWYCH**

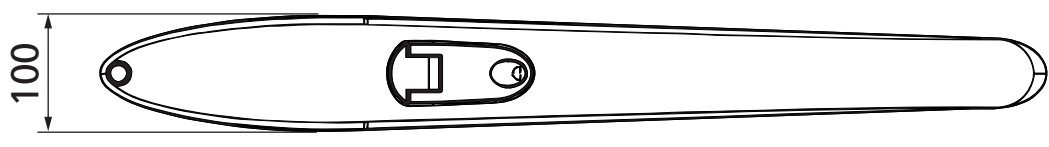
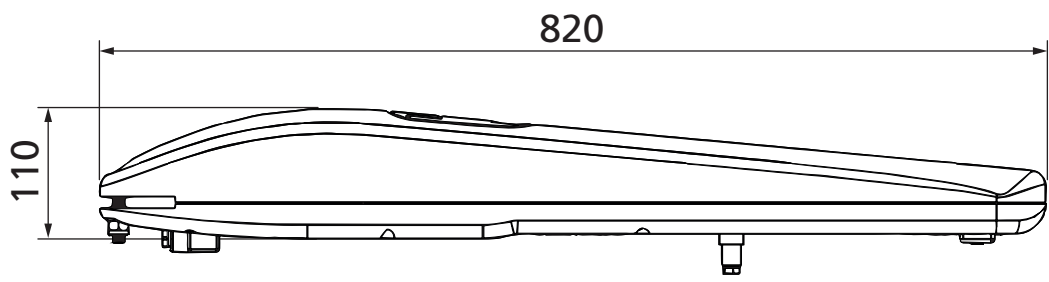

IMPORTANT REMARKS



Prior to proceeding with installation, it is essential the instructions be read in full, since they contain important information regarding safety, installation, use and maintenance.

AUTOMATION MUST BE IMPLEMENTED IN COMPLIANCE WITH THE EUROPEAN REGULATIONS IN FORCE:

EN 60204-1, EN 12453, EN 13241-1, EN 12635

- The installer must provide for a device (es. magnetothermal switch) ensuring the omnipolar sectioning of the equipment from the power supply. The standards require a separation of the contacts of at least 3 mm in each pole (EN 60335-1).
- The plastic case has an IP44 insulation; to connect flexible or rigid pipes, use pipefittings having the same insulation level.
- Installation requires mechanical and electrical skills, therefore it shall be carried out by qualified personnel only, who can issue the Compliance Certificate concerning the whole installation (Machine Directive 89/392 CEE, Annex IIA).
- Also the automation upstream electric system shall comply with the laws and rules in force and be carried out workmanlike.
- We recommend to make use of an emergency button, to be installed by the automation (connected to the control unit STOP input) so that the gate may be immediately stopped in case of danger.
- For correct installation of the system, we recommend following the instructions issued by UNAC very carefully.
- This instruction manual is only for qualified technicians, who specialize in installations and automations.
- The contents of this instruction manual do not concern the end user.
- Every programming and/or every maintenance service should be done only by qualified technicians.
- Anything not expressly described in these instructions is prohibited; unforeseen uses may be a source of danger to people and property.
- Do not install the product in explosive environments and atmospheres: the presence of inflammable gases or fumes is a serious safety hazard.
- Do not make any modifications to any part of the automation device, or the accessories connected to it, unless described in this manual.
- Any other modifications will void the warranty on the product.
- The installation steps should be conducted so as to avoid rainy weather, which can expose electronic circuits to dangerous water seepage.
- All operations requiring the casing of the device to be opened should be performed with the control unit disconnected from the electricity supply and with a warning notice displayed, for example: "CAUTION, MAINTENANCE IN PROGRESS".
- Avoid exposing the device close to sources of heat and flame.
- In the event of interventions on automatic or differential breakers or fuses, it is essential that faults be identified and resolved prior to resetting. In the case of faults that cannot be resolved using the information to be found in this manual, consult the V2 customer assistance service.

- V2 declines all responsibility for failure to comply with good construction practice standards in addition to structural deformation of the gate that might occur during use.
- V2 reserves the right to make modifications to the product without prior warning.
- Installation/maintenance personnel should wear individual protection devices (IPDs), such as overalls, safety helmets, boots and gloves.
- The ambient operating temperature should be that indicated in the technical characteristics table.
- The automation device should be shut down immediately in the event of any anomalous or hazardous situation; the fault or malfunction should be immediately reported to the person responsible.
- All safety and hazard warnings on the machinery and equipment should be complied with.
- Electromechanical actuators for gates are not intended to be used by people (including children) with diminished physical, sensory or mental capacity, or lacking in experience or knowledge, unless they are under supervision or have been instructed in use of the actuator by a person responsible for safety.

V2 has the right to modify the product without previous notice; it also declines any responsibility to damage or injury to people or things caused by improper use or wrong installation.



DISPOSAL OF THE PRODUCT

As for the installation operations, even at the end of this product's life span, the dismantling operations must be carried out by qualified experts.

This product is made up of various types of materials: some can be recycled while others need to be disposed of. Find out about the recycling or disposal systems envisaged by your local regulations for this product category.

Important! – Parts of the product could contain pollutants or hazardous substances which, if released into the environment, could cause harmful effects to the environment itself as well as to human health.

As indicated by the symbol opposite, throwing away this product as domestic waste is strictly forbidden. So dispose of it as differentiated waste, in accordance with your local regulations, or return the product to the retailer when you purchase a new equivalent product.

Important! – the local applicable regulations may envisage heavy sanctions in the event of illegal disposal of this product.

PRELIMINARY CHECKS AND IDENTIFICATION OF THE TYPE TO BE USED

It should be remembered that the device does not compensate for defects caused by improper installation, or poor maintenance, thus, prior to proceeding with installation, ensure that the structure is suitable and meets current standards and, if necessary, perform any structural modifications aimed at the implementation of safety gaps and the protection or segregation of all crushing, shearing and transit zones, and verify that:

- Your gate is equipped with a central latch.
- The gate has no friction points, either during closing or opening.
- The gate is well balanced, i.e. there is no tendency to move spontaneously when stopped in any position.
- The position identified for fixing the motor reducer allows easy and safe manual manoeuvring, compatible with the size of the motor reducer itself.
- The support on which the automation device will be fixed is solid and durable.
- The mains power supply to which the automation device is connected has a dedicated safety earthing system and differential breaker with tripping current less than or equal to 30 mA (the breaker gap distance should be greater than or equal to 3 mm).

Warning: The minimum safety level depends on the type of use; please refer to the following outline:

TYPE OF ACTIVATION COMMANDS	CLOSURE USE TYPE		
	GROUP 1 Informed people (use in private area)	GROUP 2 Informed people (use in public area)	GROUP 3 Informed people (unlimited use)
Man-present command	A	B	Not possible
Remote control and closure in view (e.g. infrared)	C or E	C or E	C and D or E
Remote control and closure not in view (e.g. radio)	C or E	C and D or E	C and D or E
Automatic control (e.g. timed closure control)	C and D or E	C and D or E	C and D or E

GROUP 1 - Only a limited number of people are authorised for use, and closure is not in a public area. Examples of this type are gates inside business premises, where the sole users are employees, or a part of them who have been suitably informed.

GROUP 2 - Only a limited number of people are authorised for use, but in this case, closure is in a public area. An example of this may be a company gate that accesses onto a public street, and which is only used by employees.

GROUP 3 - Anyone can use the automated closure, which is thus located on public land. For example the access gate to a supermarket or an office, or a hospital.

PROTECTION A - Closure is activated by means of a control button with the person present, i.e. with maintained action.

PROTECTION B - With the person present, closure is activated by a command controlled by means of a key-switch or the like, in order to prevent use by unauthorised persons.

PROTECTION C - Restricts the force of the leaf of the door or gate. I.e., in the case of the gate striking an obstacle, the impact force must fall within a curve established by the regulations.

PROTECTION D - Devices, such as photocells, capable of detecting the presence of people or obstacles. They may be active on just one side or on both sides of the door or gate.

PROTECTION E - Sensitive devices, such as footboards or immaterial barriers, capable of detecting the presence of a person, and installed in such a way that the latter cannot be struck in any way by a moving leaf or panel. These devices should be active within the entire "danger zone" of the gate. The Machinery Directive defines "Danger Zone" as any zone surrounding and/or near machinery where the presence of an exposed person constitutes a risk to the health and safety of that person.

The risk analysis should take into consideration all danger zones for the automation device, which should be appropriately protected and marked.

In a clearly visible area, apply a sign with information identifying the motorised door or gate.

The installer should provide the user with all the information relating to automatic operation, emergency opening and maintenance of the motorised door or gate.

EU DECLARATION OF CONFORMITY AND DECLARATION OF INCORPORATION OF PARTLY COMPLETED MACHINE

**Declaration in accordance with Directives: 2014/35/UE (LVD);
2014/30/UE (EMC); 2006/42/CE (MD) ANNEX II, PART B**

The manufacturer V2 S.p.A., headquarters in Corso Principi di
Piemonte 65, 12035, Racconigi (CN), Italy

Under its sole responsibility hereby declares that:
the partly completed machinery model(s):
LN MEDIUM 3000 24, LN MEDIUM 3000 230
Description: electromechanical actuator for gates

- is intended to be installed on gates, to create a machine according to the provisions of the Directive 2006/42/EC. The machinery must not be put into service until the final machinery into which it has to be incorporated has been declared in conformity with the provisions of the Directive 2006/42/EC and 89/106/CE.
- is compliant with the applicable essential safety requirements of the following Directives:
Machinery Directive 2006/42/EC (annex I, chapter 1)
Low Voltage Directive 2014/35/EU
Electromagnetic Compatibility Directive 2014/30/EU
Directive ROHS-3 2017/2102

The relevant technical documentation is available at the national authorities' request after justifiable request to:
V2 S.p.A., Corso Principi di Piemonte 65, 12035, Racconigi (CN), Italia

The person empowered to draw up the declaration and to provide the technical documentation:

Roberto Rossi

Legal representative of V2 S.p.A.
Racconigi 01/03/2024



DESCRIPTION OF THE PRODUCT

This product has been designed to automate gates or doors with leaf opening, for residential or industrial use.

CAUTION!

Any other use different to that described and in ambient conditions different to those set out in this manual is to be considered improper and forbidden! The product is an electromechanical gear motor, equipped with motor and an endless screw reduction gear.

The gear motor is powered by the external control unit to which it is connected.

In the event of a black out, it is possible to move the gate leaves by hand, unblocking the gear motor manually.

TECHNICAL DATA

		LN MEDIUM 3000 230	LN MEDIUM 3000 24
Max. leaf length	m	3	3
Max. leaf weight	Kg	600	600
Power supply		230Vac	24Vdc
Idling current	A	1	0,8
Full load current	A	1,6	15
Electric power	W	200	120
Opening time of the leaf 0÷90°	s	18,5	15
Max travel	mm	360 (300)	360 (300)
Operating speed	m/s	0,016	0,013 ÷ 0,016
Maximum thrust	N	2000	2000
Working temperature	°C	-20 ÷ +55	-20 ÷ +55
Protection	IP	44	44
Working cycle	%	30	90
Motor weight	Kg	8	7

INSTALLATION LAYOUT

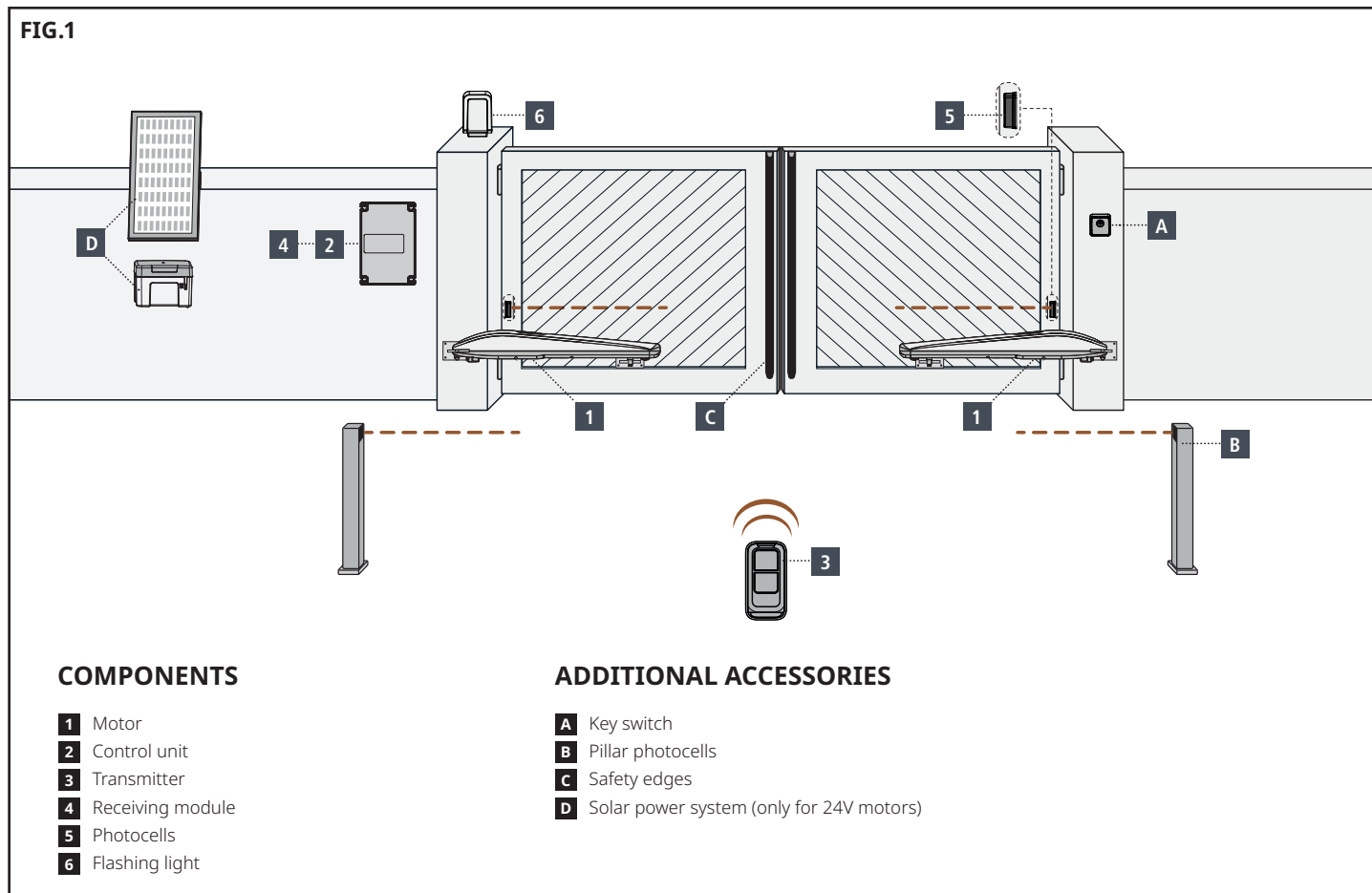

LENGTH OF THE CABLE	< 10 metres	from 10 to 20 metres	from 20 to 30 metres
Power supply (230V)	3G x 1,5 mm ²	3G x 1,5 mm ²	3G x 2,5 mm ²
24V motor power supply	2G x 1,5 mm ²	2G x 1,5 mm ²	2G x 2,5 mm ²
230V motor power supply	4G x 1,5 mm ²	4G x 1,5 mm ²	4G x 2,5 mm ²
Photocells (TX)	2 x 0,5 mm ²	2 x 0,5 mm ²	2 x 0,5 mm ²
Photocells (RX)	4 x 0,5 mm ²	4 x 0,5 mm ²	4 x 0,5 mm ²
Key switch	2 x 0,5 mm ²	2 x 0,5 mm ²	2 x 0,5 mm ²
Safety edges	2 x 0,5 mm ²	2 x 0,5 mm ²	2 x 0,5 mm ²
Flashing light	2 x 1,5 mm ²	2 x 1,5 mm ²	2 x 1,5 mm ²
Antenna (integrated into the flashing light)	RG174	RG174	RG174
ECO-LOGIC (accumulator unit)	2 x 1,5 mm ²	-	-
ECO-LOGIC (solar panel)	2 x 1 mm ²	-	-

INSTALLATION MEASURES

To carry out a proper installation of the operator parts as well as to ensure the best automation performance, the measurement levels shown in the following table shall be complied with.

Change the gate structure to adapt it to one of the cases in the table, if necessary.

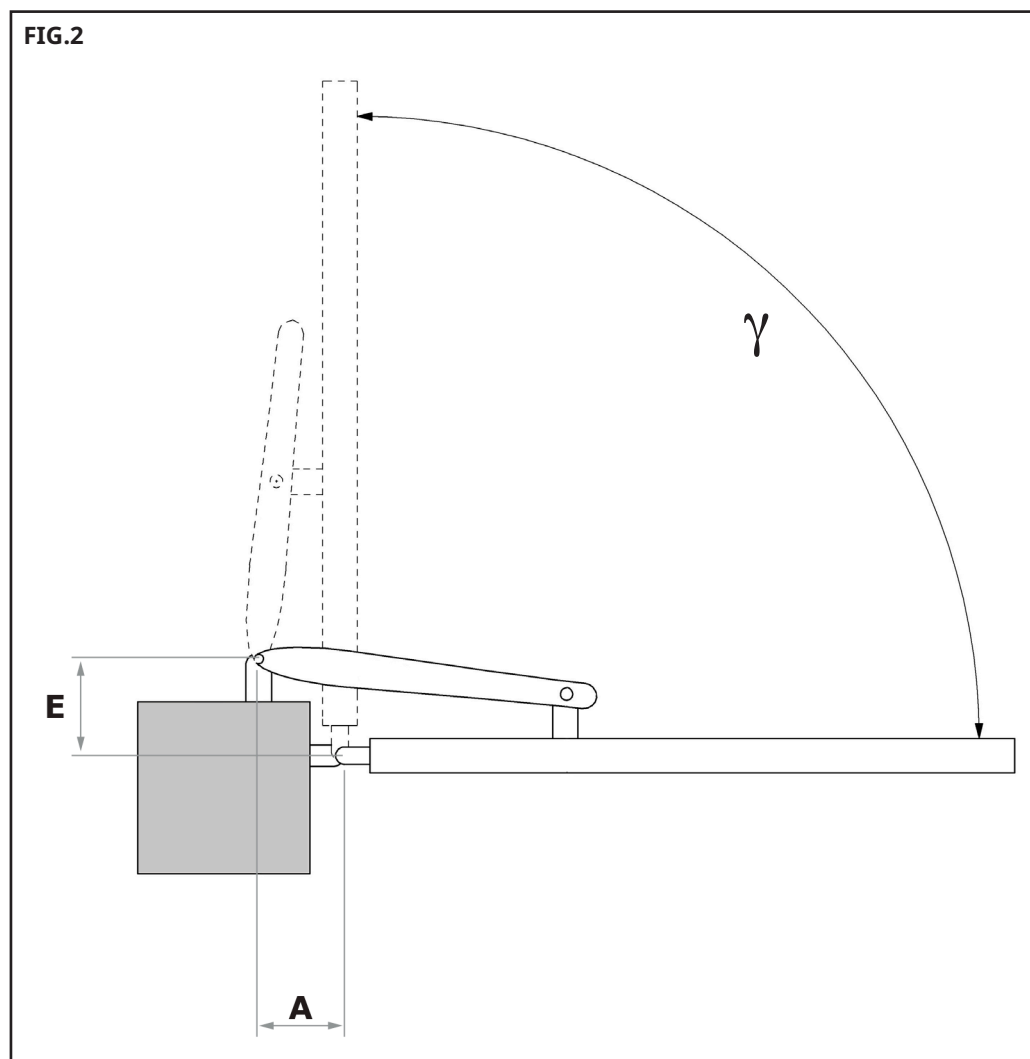

γ	E [mm]	A [mm]
90°	130	170
	140	165
	150	160
	160	150
	170	150
	180	145
	190	135
100°	200	130
	130	155
	140	150
	150	145
	160	140
	170	140
110°	180	135
	130	155
	140	155

BRACKETS HEIGHT

Fix the brackets keeping 54 mm between the surfaces in order to fix the gear-motor horizontally. (FIG.3).

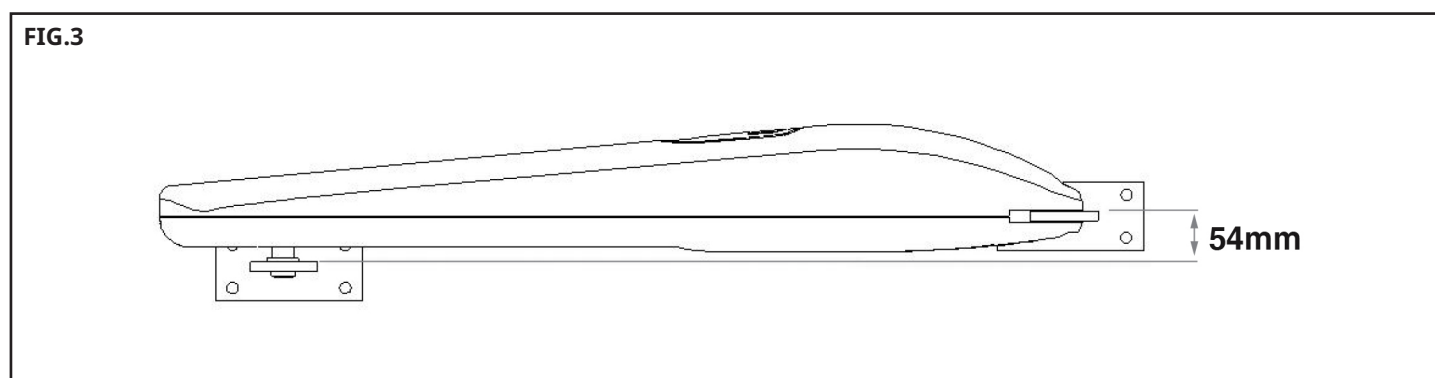

FIXING THE GEAR-MOTOR TO THE BRACKETS

Fixing the gear-motor to the rear brackets. (FIG. 4).

Fixing the gear-motor to the front brackets (FIG. 5).

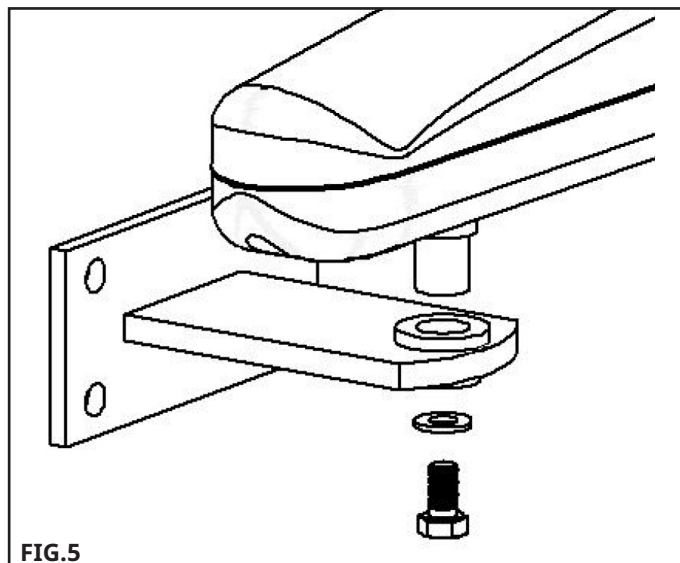
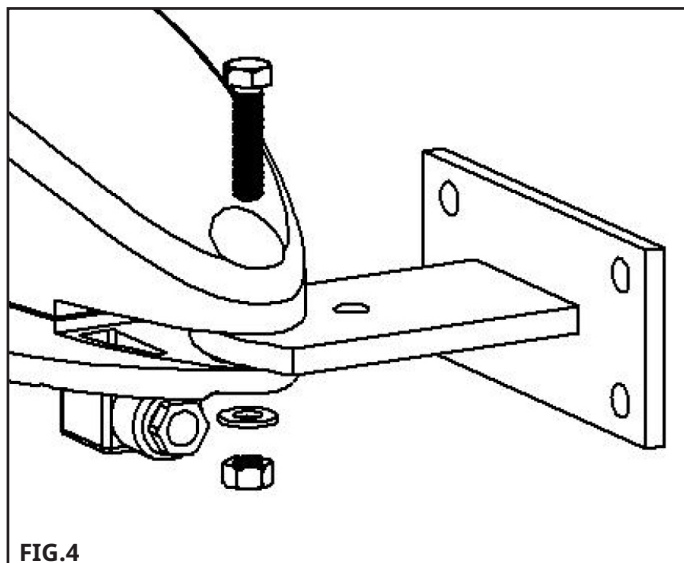

MANUAL OVERRIDE

Before operating the manual override disconnect the power.

Manual override has been thought for manual opening of the gate in case of power-cut or motor breakdown.

- Insert the key in the cylinder lock and turn it of 90° clockwise direction.
- Pull the lever till it is perpendicular to the gear-motor

RESTORE

- Bring back the lever in the original position.
- Insert the key in the cylinder lock and turn it of 90° anticlockwise direction.

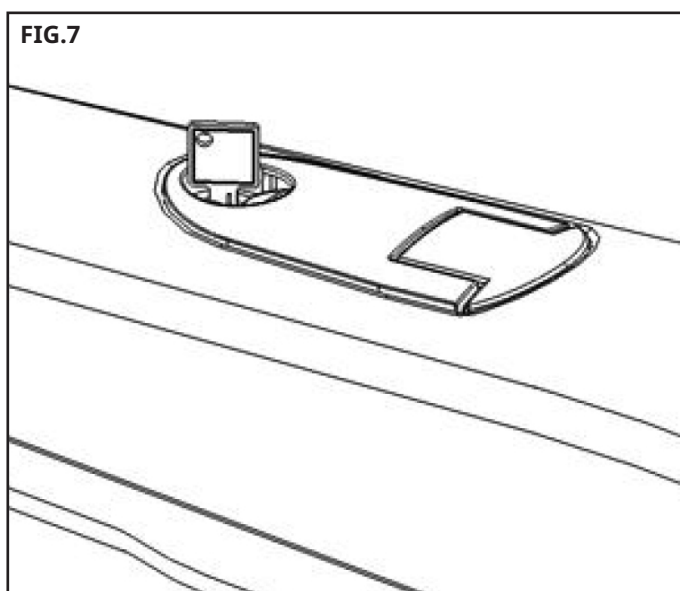
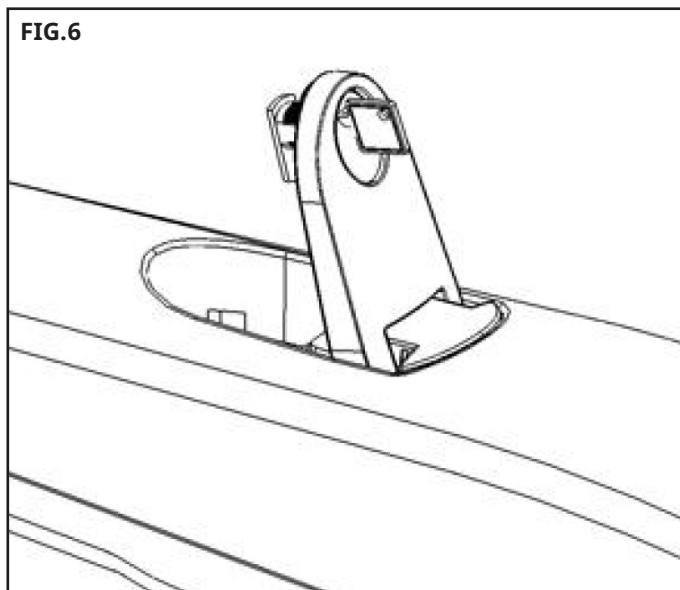

ELECTRICAL CONNECTION

CAUTION!

- A wrong connection can cause faults or danger; therefore follow scrupulously the connections set out.
- Perform the connection operations when the electricity is off.

The actuator is provided with the assembled connector.

Disassemble the connector by unscrewing the screw "A", then connect the wires according to the diagram below.

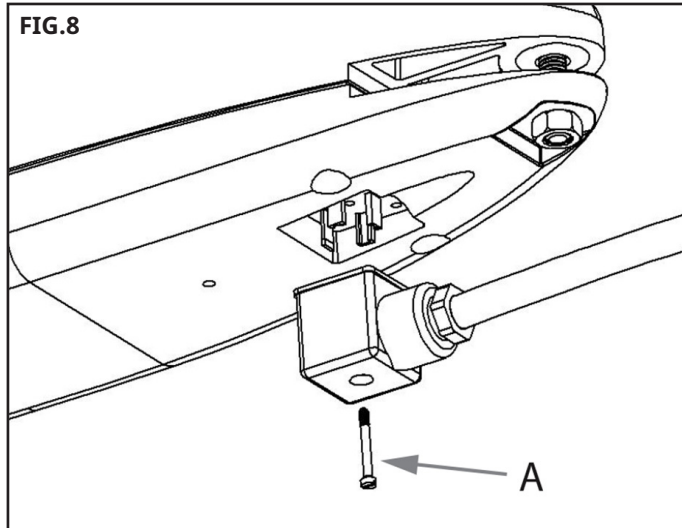

LN MEDIUM 3000 24

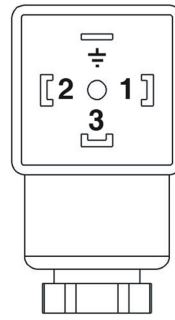

1 - MOTOR (+)

2 - MOTOR (-)

3 - NOT USED

 - GROUND

LN MEDIUM 3000 230

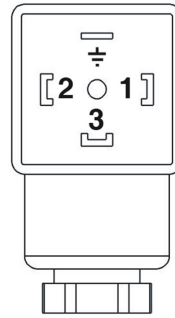

1 - PHASE 1

2 - PHASE 2

3 - COMMON

 - GROUND

To check the connections, direction of rotation of the motor, phase shift in the movement of the leaves and setting the limit switch, refer to the instructions manual of the control unit.

STOP ADJUSTMENT

The mechanical-stop enables to stop the gate at a required position, avoiding the door to hit the stop devices.

- Set the gear-motor on manual override (FIG. 6).
- Twist off the screw of the mechanical-stop (B or D).
- Move the door to the desired opening/closing position.
- Place the mechanical-stop next to the sliding pin (C).
- Turn the screw tightly.
- Set the gear-motor on automatic functioning (FIG. 7).

⚠ WARNING: The gear-motors are normally provided with mechanical stop in open position. In case of lack of external mechanical stop in closing position, it is possible to buy the optional mechanical stop.

FIG.9

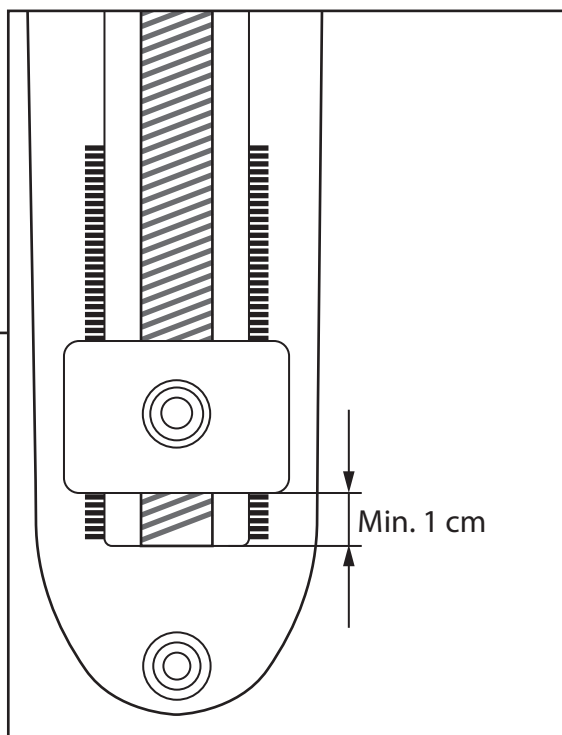
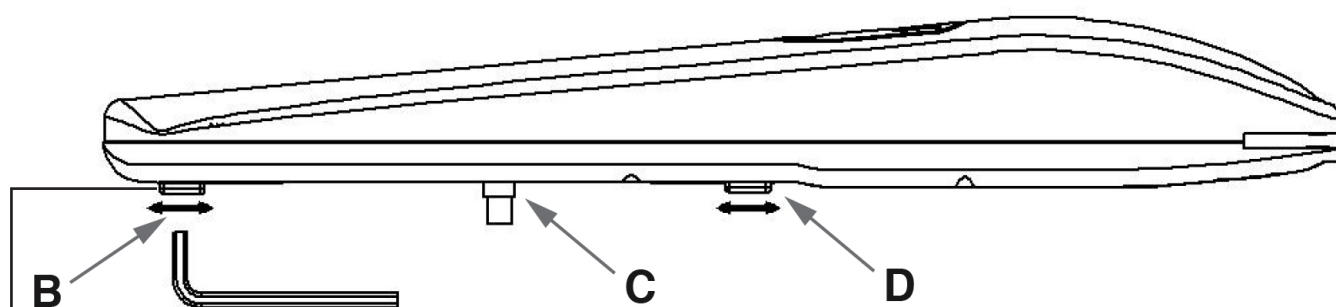

⚠ ATTENTION: the front mechanical stop must not be in contact with the engine cover. Keep a minimum distance of 1 cm



+39 0172 812411

Technical support
Monday/Friday 8.30-12.30 ; 14-18
(UTC+01:00 time)

Dati dell'installatore / *Installer details*

Azienda / Company _____

Timbro / Stamp _____

Località / Address _____

Provincia / Province _____

Recapito telefonico / Tel. _____

Referente / Contact person _____

Dati del costruttore / *Manufacturer's details*

V2 S.p.A.

Corso Principi di Piemonte 65/67

12035 RACCONIGI CN (ITALY)

Tel. +39 0172 812411 - Fax +39 0172 84050

info@ableautomation.com

ableautomation.com



ZIS733

EDIZ. 04/03/2024